

APPLICATION:

PRODUCT NAME:  
**VACUUM BREAKER ANTI-SPILL  
 SATIN CHROME**

JOB NAME:

\_\_\_\_\_ SPECIAL CONFIGURATION  
 (CHECK BASE MODEL AND OPTIONS)

QUANTITY:

ITEM NO.:

MODEL:

14443

OPTIONS OR MODIFICATIONS:

OTHER \_\_\_\_\_

FEATURES:

- \* ANTI-SPILL DESIGN
- \* ASSE - 1056 APPROVED

SYSTEM LIMITS

- \* TEMP: 33°F MIN. TO 180°F MAX.
- \* PRESSURE 8 PSI (MIN) - 150 PSI (MAX)

SHIPPING WEIGHT

- \* 2.0 LBS

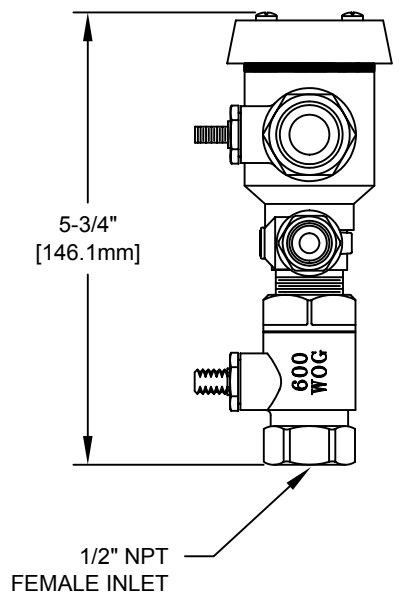
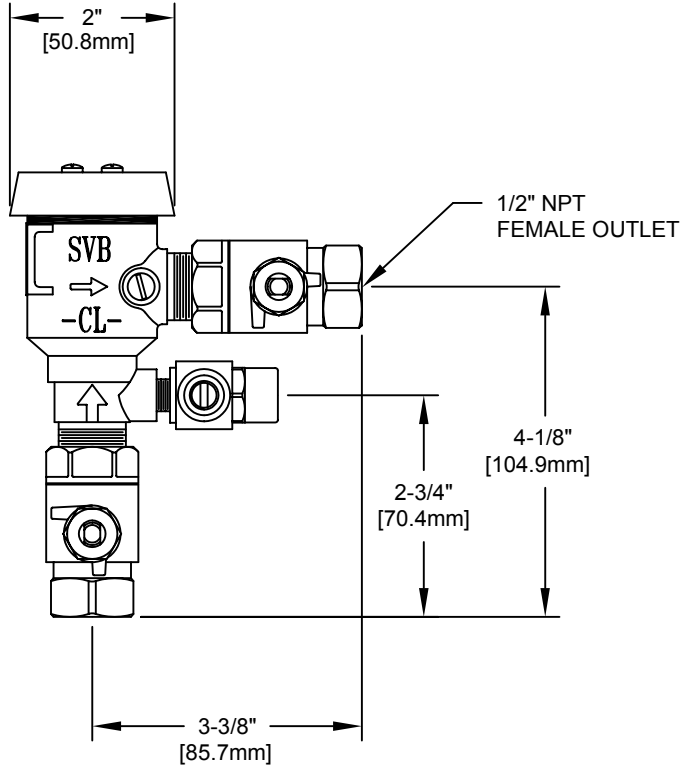

ANSI/A112.18.1M, ANSI/NSF 61.9



FISHER MANUFACTURING COMPANY  
 TOLL FREE: 800-421-6162 - FAX: 800-832-8238  
 information@fisher-mfg.com - www.fisher-mfg.com